



12, 15 and 20 Series Drills Fertilizer Option

Used with:

- 1200 and 1210
- 1500 and 1510
- 2000 and 2010



When you see this symbol, the subsequent instructions and warnings are serious - follow without exception. Your life and the lives of others depend on it!

General Information

These instructions explain how to install the fertilizer option. The fertilizer option allows the operator to seed and apply dry fertilizer in the same field pass. The fertilizer box is mounted behind the main drill box.

Manual Update

Refer to the drill operator's manual for detailed information on safely operating, adjusting, troubleshooting and maintaining the fertilizer option. Refer to the parts manual for part identification.

- 12, 15 and 20 Series Drill Operator's Manual . . . 118-389M-A
- 12, 15 and 20 Series Drill Parts Manual. 118-389P

Definitions

Right and left as used in this manual are determined by facing the direction the machine will travel.

Assembly Instructions

Mounting Box

Refer to Figure 1.

1. Remove handles (1) and 1/2-inch flange bolts (2) and nuts from left-hand seed box. Install handles on fertilizer box as shown.
2. Remove top 5/16-inch hex flange bolts (3) from rear of seed box. Save bolts and nuts for later use in the same holes.
3. Remove four 3/8-by-1-inch hex flange bolts (4). Save bolts and nuts for later use in the same holes.
4. Bolt fertilizer box (5) to drill. At right-hand end, use 3 3/8-by-1-inch hex flange bolts (4) removed in step 3. Add reinforcement strap (6) supplied in fertilizer kit to inside of seed box. At the other end of box, bolt fertilizer box to seed box using 1/2-by-1-inch hex flange bolts (7) and locking flange nuts (8) supplied in fertilizer kit.
5. Bolt fertilizer box to drill frame outside frame rail using 1/2-by-1 1/4-inch hex bolts (9), nuts and lock washers (10).
6. Replace 5/16-inch hex flange bolts (3) removed in step 2. Pass bolts through spacer bracket between seed and fertilizer box.
7. On 15-foot drills, slip flex couplers (11) onto box shafts as shown.
8. On 15- and 20-foot drills, install right-hand fertilizer box. At center of drill, allow both fertilizer boxes to hang on seed box until lower 5/8-by-2-inch bolt (12) is installed.
9. If you are installing a 15-foot box, check alignment of fertilizer shafts at flex couplers (11) at center of drill. The flex couplers should be loose; neither flex coupler should have the weight of the opposite box hanging on it. The hex shafts should be extended toward center of drill far enough to engage the entire bore of the flex couplers. The gap between shafts at the center should be 7/8 inch (22 mm) on a 15-foot drill.
10. Tighten all bolts and nuts.

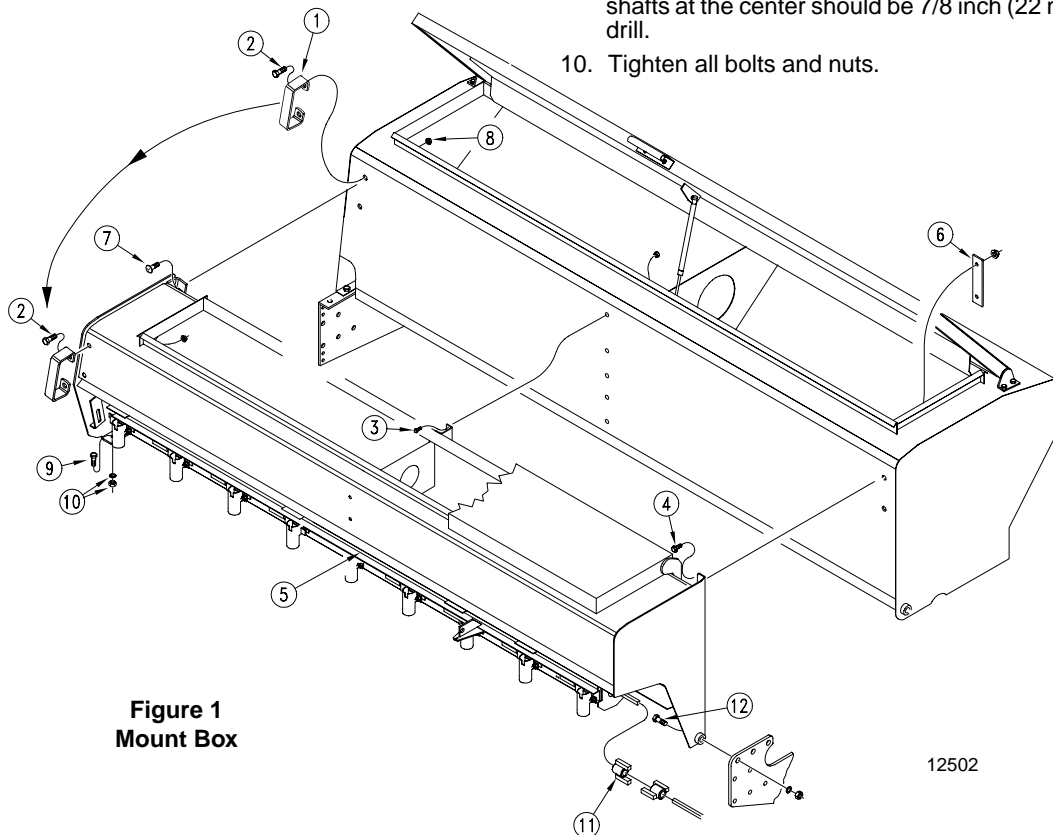

Figure 1
Mount Box

12502

Assembly

Installing Drive

Refer to Figure 2.

1. Working at front, left-hand side of drill, remove two front 1/2-by-1-inch bolts (13) that join seed box to drill frame. Install the left-hand bearing bracket (14) using 1/2-by-1 1/2-inch bolts (13) and flat washers from fertilizer kit. Leave these bolts loose.
2. Relieve tension on chain (15) that runs from gearbox-output sprocket to seed jackshaft. Remove two 3/8-by-1 1/2-inch bolts (16) that join sprocket and bearing assembly (17) to gauge-wheel bracket. Bolt idler plate (18) to gauge-wheel bracket reusing two 3/8-by-1 1/2-inch bolts (16) plus a third from fertilizer kit. Leave these bolts loose.
3. Install two hex-bore bearings (19) on plates (14 and 18) using flangettes (20) and 5/16-by-1-inch carriage bolt (21) and hardware as shown. Be careful to place bearings on side of plates as illustrated.
4. Slide 7/8-inch hex jackshaft (22) through bearing mounted above gauge wheel. Slip shaft through 29-tooth sprocket (23) and into bearing near end of seed box. Secure shaft by driving a roll pin (24) on outside of bearing (19) and 12-tooth sprocket (25).
5. Unscrew acrometer (26) from gauge-wheel jackshaft. Install 3/4-inch hex bore, 14-tooth sprocket, (27) using roll pin (28). Orient sprocket as shown. Re-install acrometer.
6. Install 17-tooth ball bearing idler sprocket (29) in slot using the 5/8-by-3 1/2-inch, full-threaded bolt, flat washer, lock washer and jam nut (30). Install plastic 12-tooth idler sprocket (31) as shown. Install but do not tighten 132-pitch, gauge-wheel-drive chain (32).

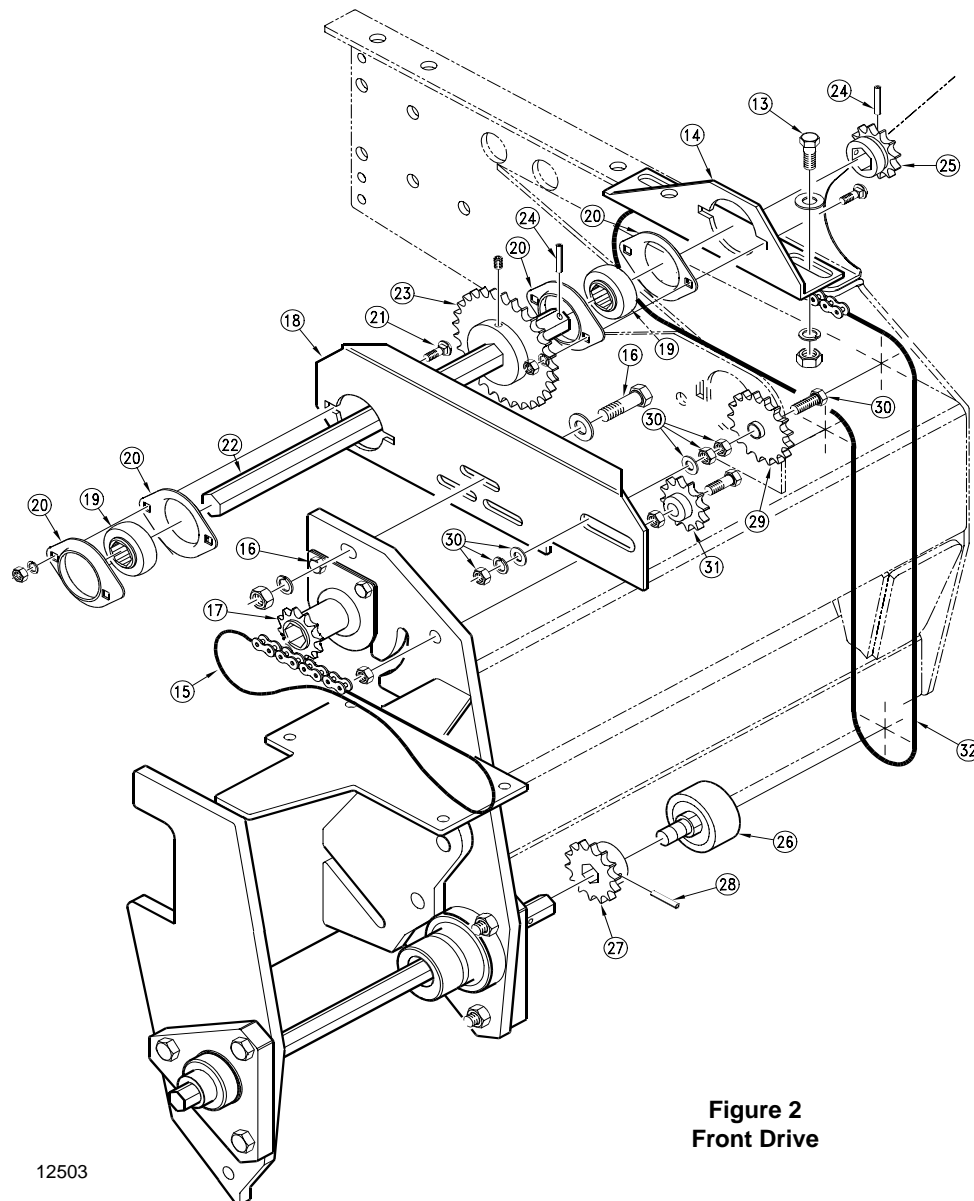

Figure 2
Front Drive

12503

Assembly

Refer to Figure 3.

7. Working on rear of drill, install two flush-mount bearings (33) using 5/16-by-1-inch carriage bolts (34), nuts and lock washers supplied with fertilizer kit. Install jackshaft (35) in bearings, and slip 17-tooth (36) and 12-tooth sprocket (37) over shaft as shown. Mount 12-tooth idler sprocket (38) to slotted bracket using 1/2-by-1 1/4-inch hex bolt (39), jam nut (40), flat washers (41) and nylock jam nut (42).
8. Align lower 12-tooth sprocket (37) with fertilizer box sprocket (43).

NOTE: On drills with 00 Series, straight-arm openers, position these sprockets and chain so they are not directly over an opener spring rod.

9. Install 56-pitch chain (44). Remove slack with idler sprocket.

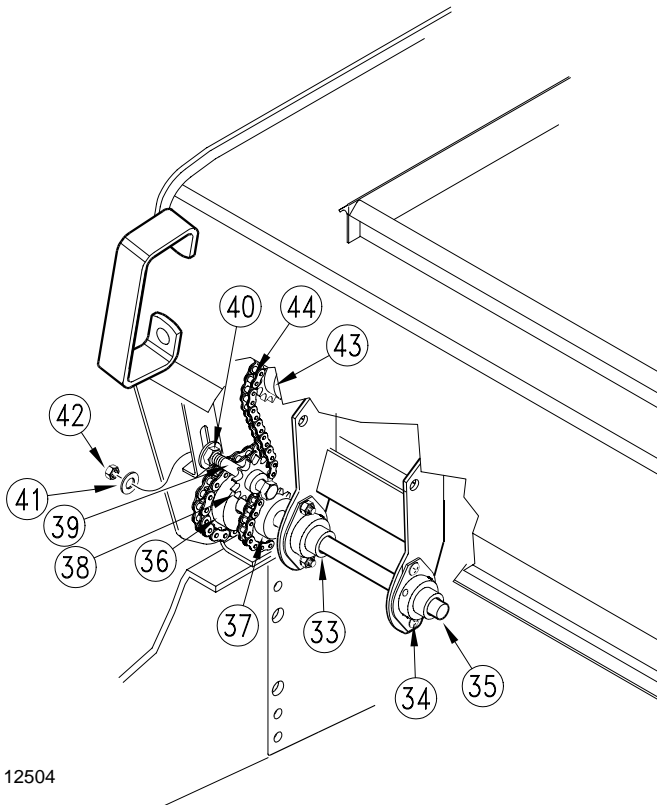

Figure 3
Rear Drive

Refer to Figure 4.

10. Thread drive chain (45) back through cutout in box, around rear sprocket and back to front 12-tooth sprocket (46). After connecting chain, check sprocket alignment. Move rear sprocket if necessary. To tighten this chain, move jackshaft (47) forward by using the slots in bearing plates (48 and 49). After removing excess slack, tighten bolts holding both plates. Tighten the idler for the gearbox output chain that was loosened when you started.
11. To remove excess slack from chain coming from gauge wheel, move 17-tooth, ball-bearing idler sprocket (29) and tighten.

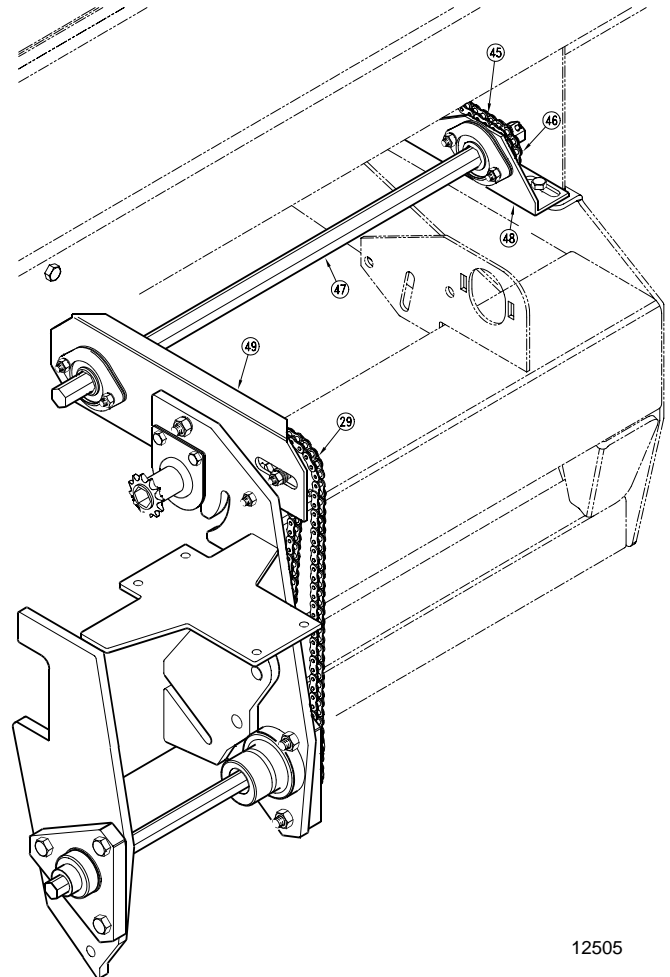

Figure 4
Chain Installation

12. On 20-foot drills, repeat steps to install right-hand drive.